

SAMUEL HEATH

Product data sheet

R106FS POWERMATIC FREE SWING DOOR CLOSER

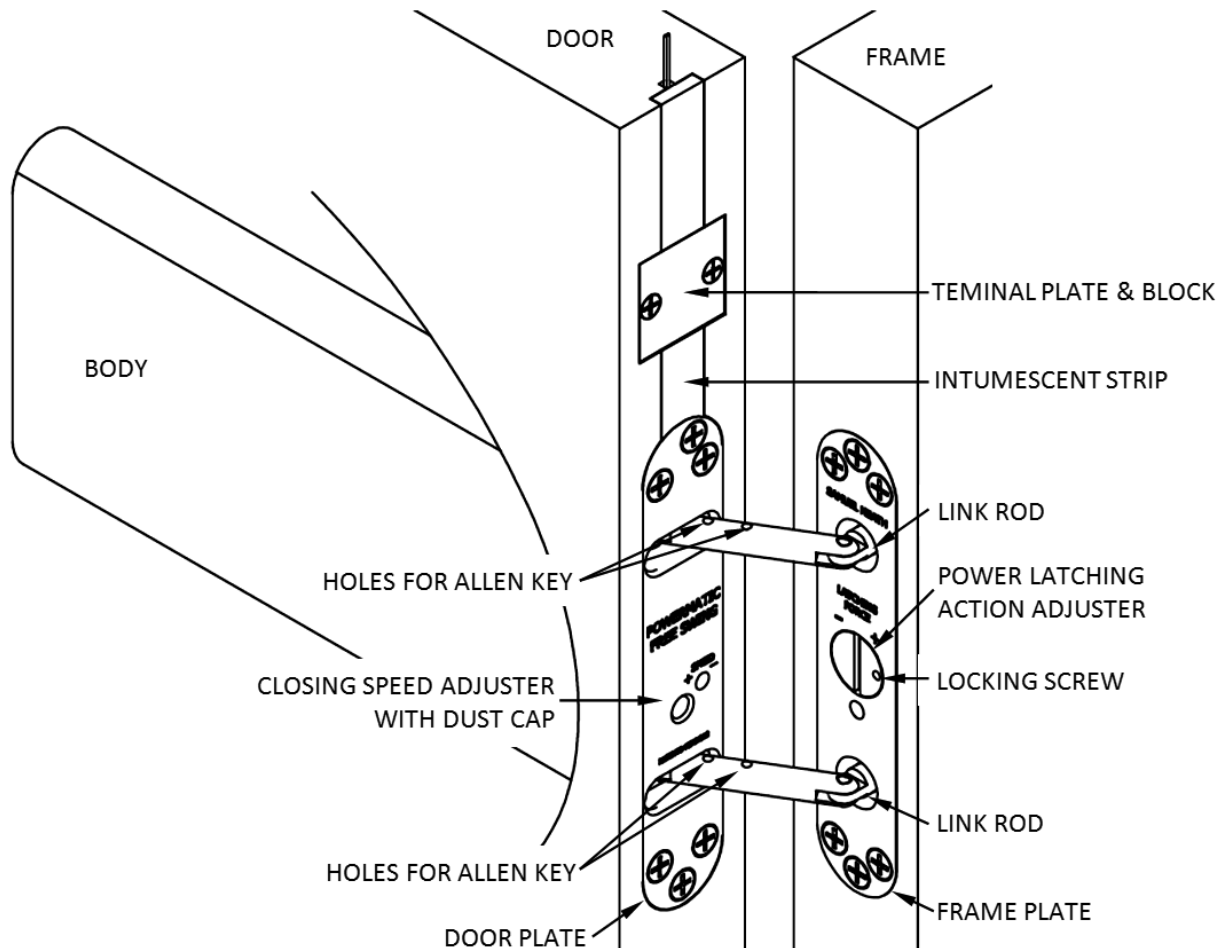

The Powermatic Free Swing Door Closer, once installed with a power supply, allows the door to operate normally and function the same as a door without a closer fitted.

The Powermatic Swing Free Door Closer should be installed in conjunction with a 24 volt DC fire alarm system which cuts the power to the closer in the event of a fire.

Once the power supply is interrupted, the Powermatic Free Swing Door Closer will close the door.

PLEASE READ FITTING INSTRUCTIONS THOROUGHLY BEFORE INSTALLATION

SAMUEL HEATH
since 1820

General

Powermatic Free Swing has all the features and specifications of the standard Powermatic. Linked to a 24 volt fire alarm system, Powermatic Free Swing allows the door to be manually operated and left open as desired once the door closers mechanism has been simply primed. On activation of the fire alarm system, or should the power fail or be switched off, Powermatic Free Swing automatically closes the door at a controlled rate.

Powermatic Free Swing is suitable for use in any building where permanently closed doors are not desirable or required by legislation.

R106FS Schematic

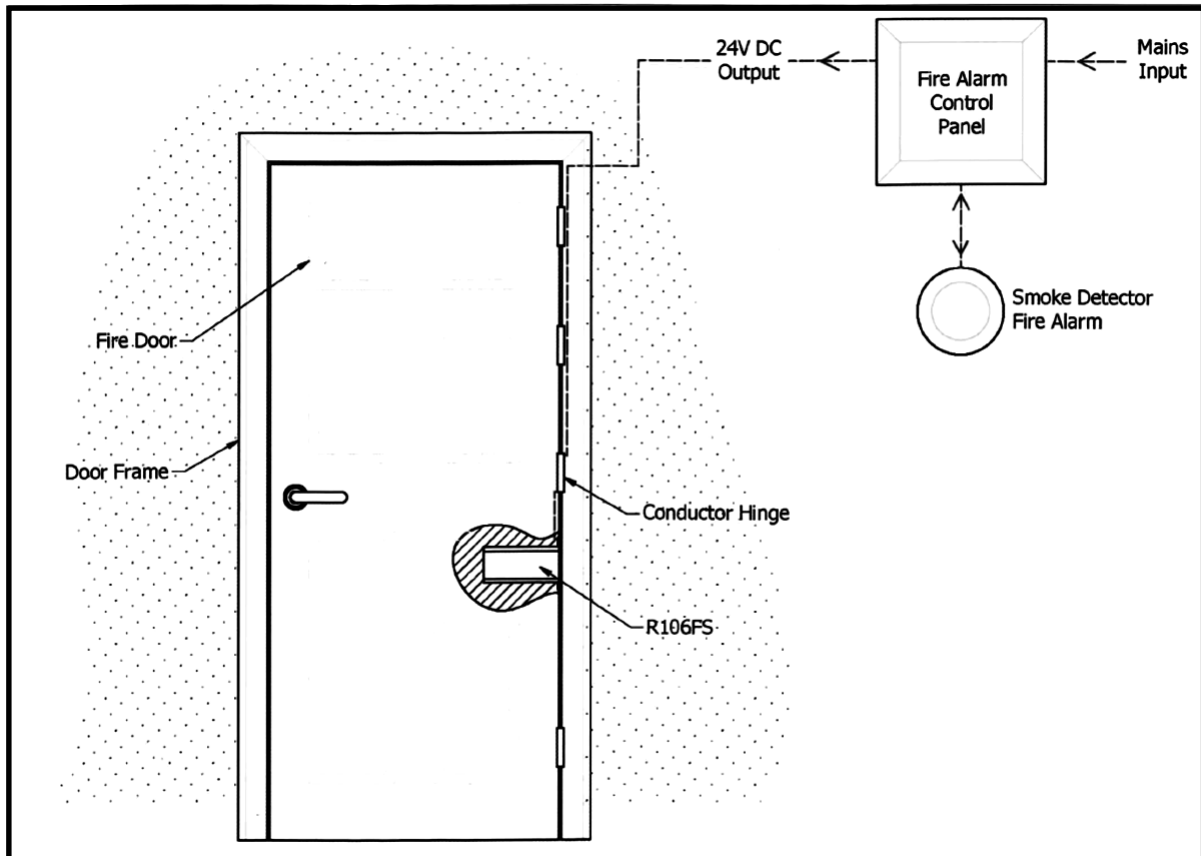

3 STAGES

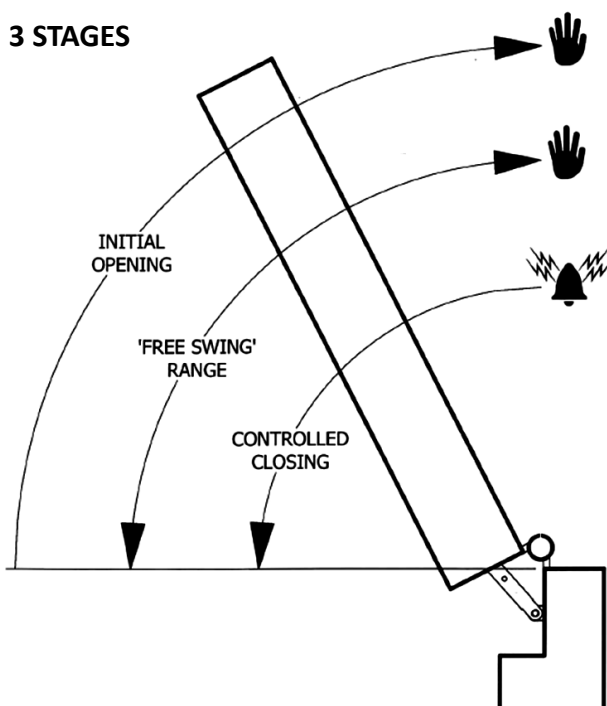

1. With the power supply on, when the door is initially opened to its maximum the closing mechanism will be primed and held ready for release when required.

2. The door is now in the 'Free Swing' mode and can be manually opened, closed and left ajar as desired.

3. When the fire alarm is activated, power switched off or in the event of a power failure the closing mechanism will be released and the door will close automatically.

Dimensions

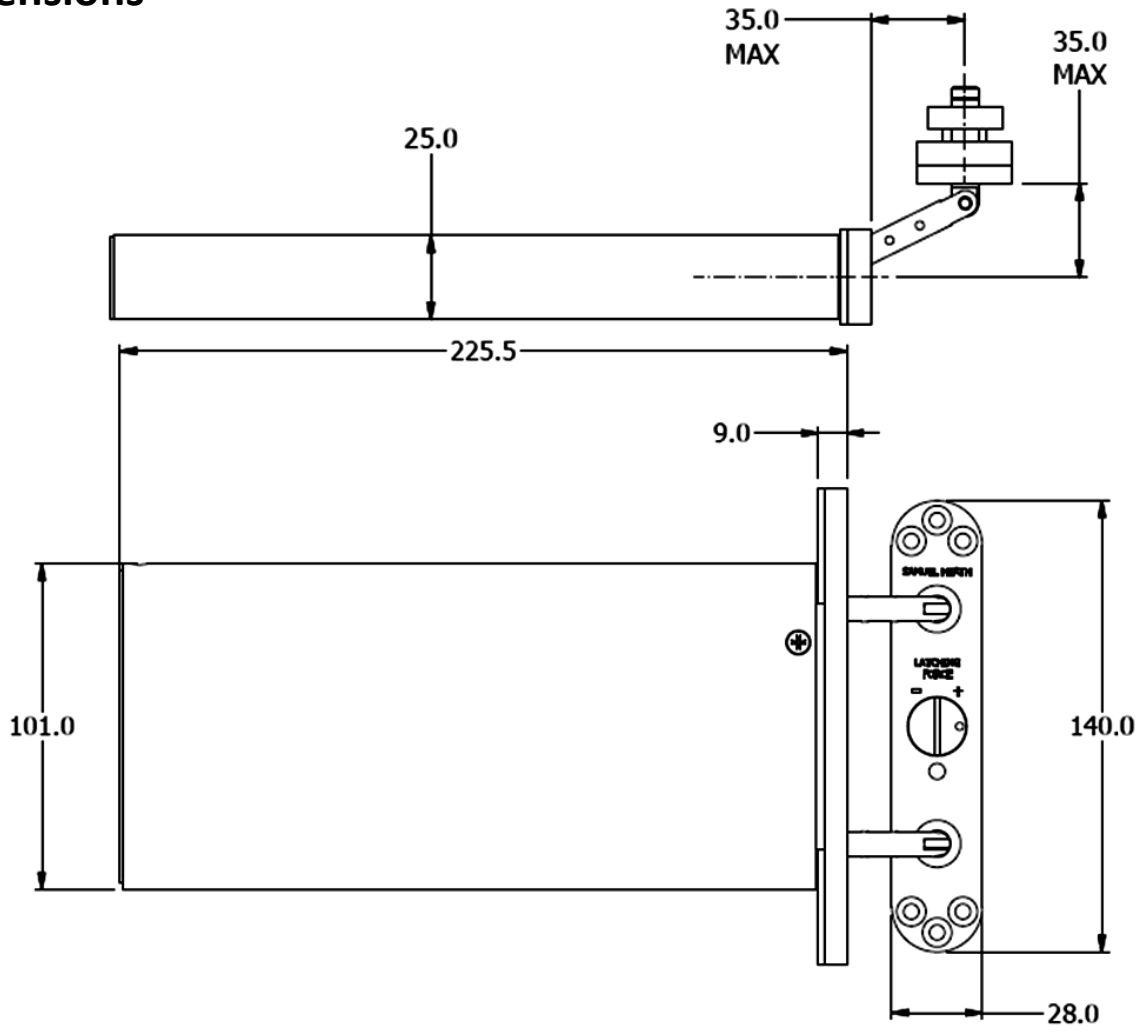

Terminal Block Kit

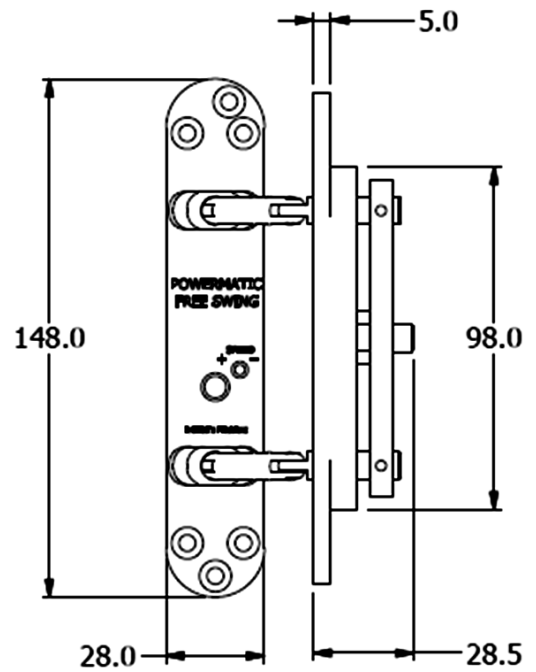
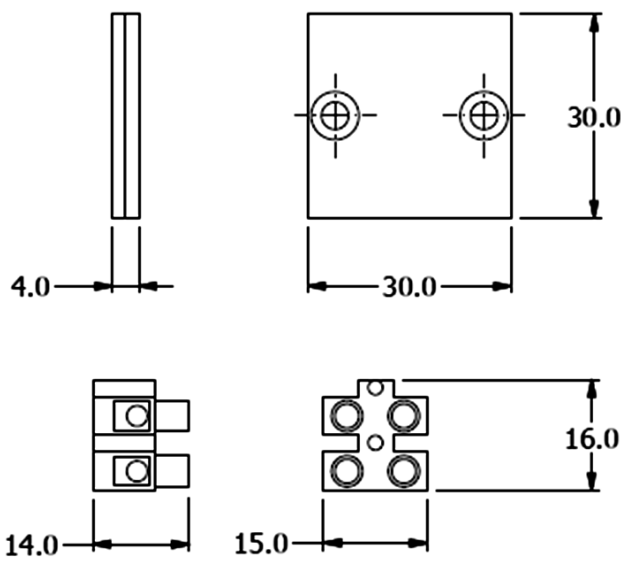

Parts list

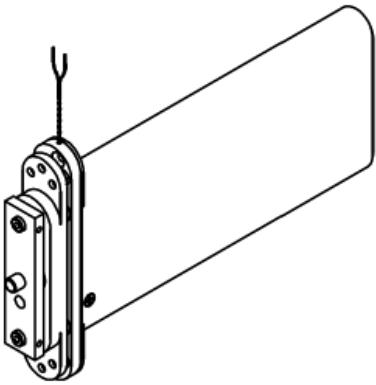

Door Closer x1

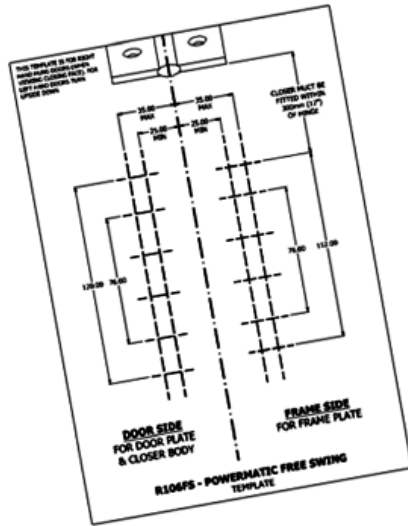

Template x1



Allen Keys x2 (B)

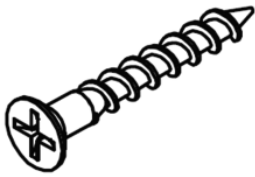

Fixing Screws x12 (C)



Extractor Bolt x1 (A)



Adjuster Screw Allen Keys x1 (D)

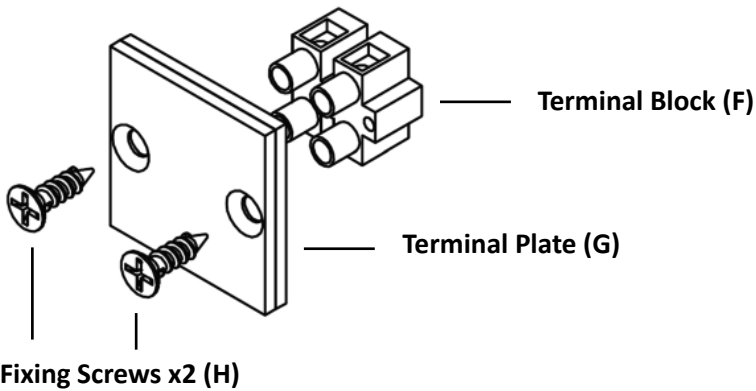

Terminal Block Kit x1

CHECK ALL COMPONENT PARTS AGAINST PARTS LIST.

Tools Required

- Screwdriver (Plain Slotted)
- Screwdriver (Phillips)
- Wood Chisel 25mm x 226mm
- Solid Centre Auger Bit or Spade Bits 26mm Ø, 28mm Ø and 19mm Ø
- Bradawl
- Power Drill
- Tape Measure
- Pencil
- Adjustable Spanner
- Ruler
- Electric Screwdriver
- Wood Chisel 10mm wide

NOTE: The use of a dedicated morticing tool is highly recommended for multiple installations.

**Order code R98.XX
and extra long shaft R96.XX
www.morticer.com**

**A DBB morticer, a long shaft and WB27
and WB29 cutters will be required**

Eye Protectors, Ear Defenders and a Face Mask are recommended during installation of the Powermatic Free Swing Door Closer

IMPORTANT NOTICE

1 DOOR CLOSERS FITTED TO A FIRE DOOR

- CE marked and adjustable to conform to power size 3 of controlled door closing devices BSEN1154 (test door 60kg) when the power latching action is set to maximum.
- Swing free operation in accordance with BSEN1155
- 1 Hour fire test BSEN1634-1:2000
- Adjustable speed control.
- The Powermatic Free Swing conforms to BSEN1155 when fitted to a fire alarm circuit providing 24 VDC (Min 0.9 amps). Power to the Powermatic Swing Free should be routed through a suitable conductor hinge, concealed loop or similar fire rated device, and then into the intumescent channel in the door to conceal the wires behind the intumescent strip (see point 10).
- A terminal block and cover plate are provided to connect the power supply to the Powermatic Free Swing. The terminal block and cover plate should be positioned in accordance with the drawing in point 4.
- Turn adjuster screw fully to positive (+) as explained in 9.
- Closer and plates should be bedded in Alfacryl FR Intumescent Acrylic Mastic available from Samuel Heath.
- If no power is supplied to the product it will operate as a continuous door closer in accordance with BSEN1154

2 TEMPLATE POSITIONING

- Ensure door is plumb, hinges are free, and that timber is sound.
- Take template provided and fold along centre line. Open door to 90°.
- Secure template to door edge and frame edge no more than 1000mm from floor and within 300mm of a hinge ensuring the centre line is aligned with the pivot point of the hinge.
- Draw a vertical line at the centre point of the door edge on the template.
- **NB This line must not exceed 35mm from template centre line.**
See Fig. 1

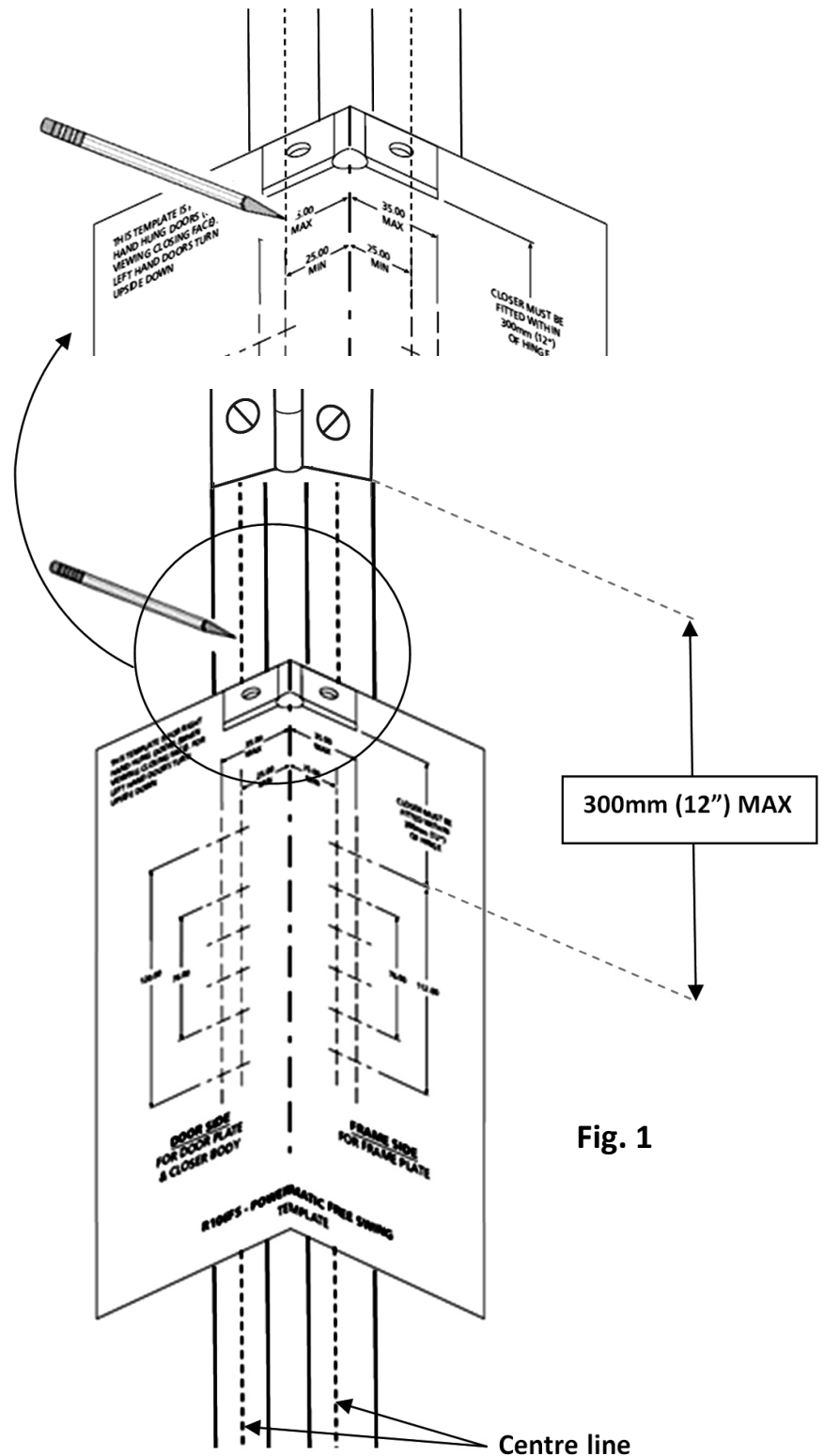
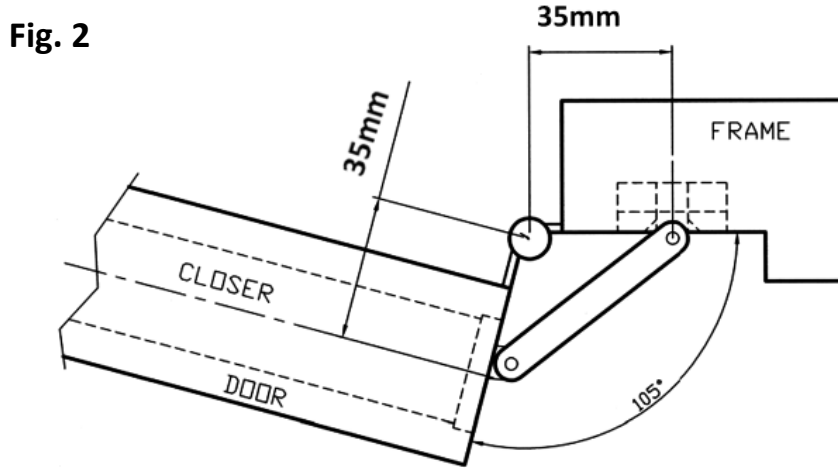

Fig. 1

- Draw a vertical line onto the frame side at the same distance from the centre line.
- At each point on the template where the vertical pencil lines cross the horizontal dotted lines mark through the template using a bradawl into the door edge and frame edge to establish drilling points. Remove template RETAIN FOR REFERENCE.
- Note: Door can now be removed from frame to assist drilling if preferred.

To achieve a maximum opening angle of 105° the centre of the closer must be no more than 35mm from the pivot point of the hinge.



IMPORTANT

To ensure the 35mm distance is not exceeded the closer and fixing plate can both be offset in the door leaf and jamb (closer to the hinge pivot point) by up to a maximum of 6mm as illustrated below.

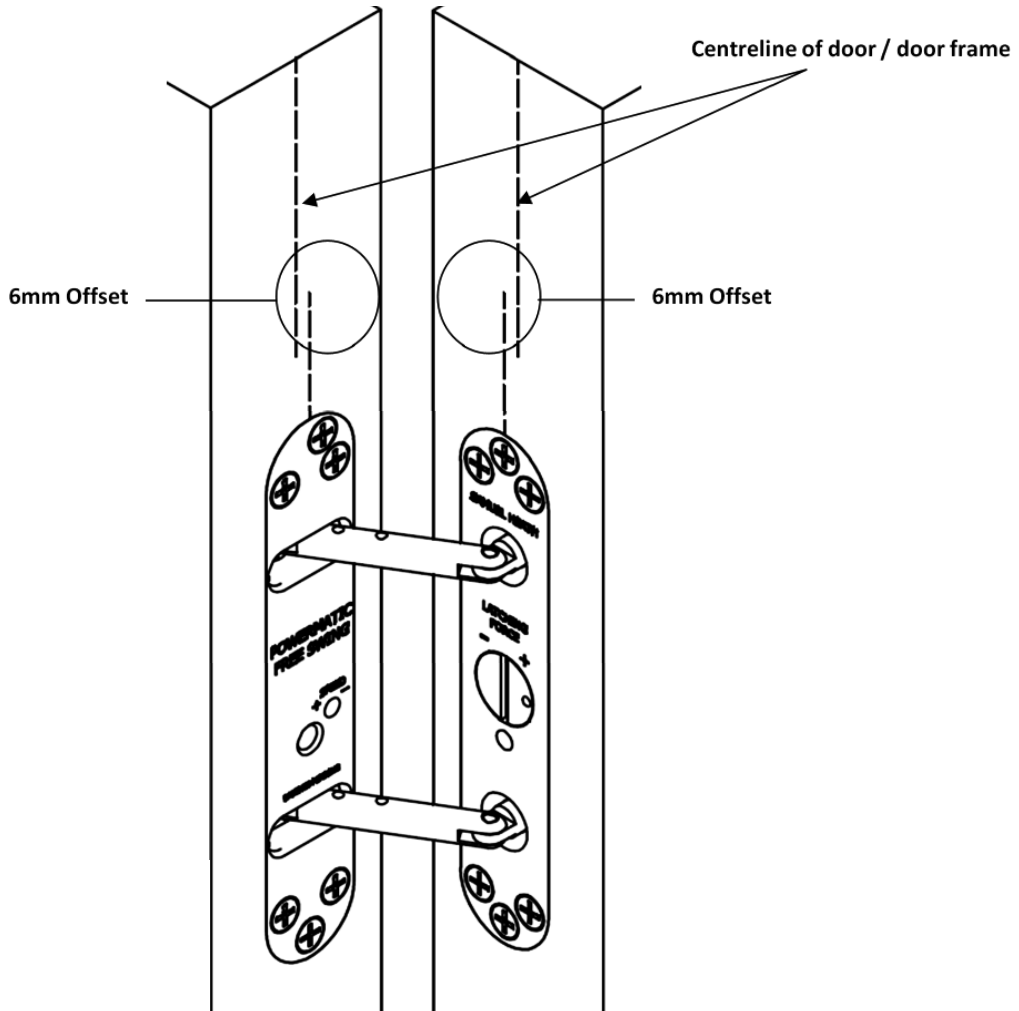

3 FRAME PREPARATION FOR FRAME PLATE

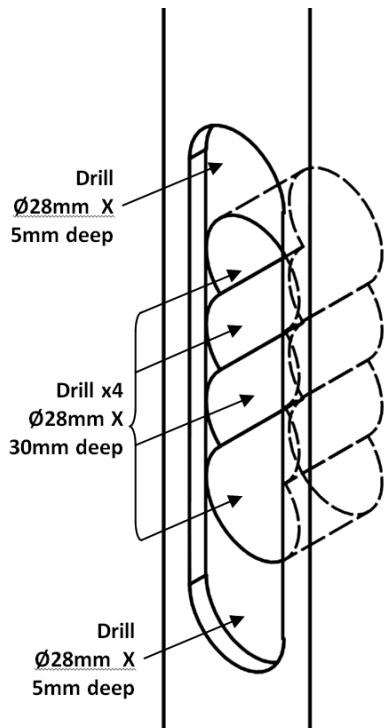

NB To ensure correct operation of closer there must be a 3mm gap between the two fixing plates when the door is in the closed position. These instructions are based on the gap between door and frame being 3mm +/- 1.0mm.

4 DOOR PREPARATION FOR BODY & DOOR PLATE, TERMINAL BLOCK AND COVER

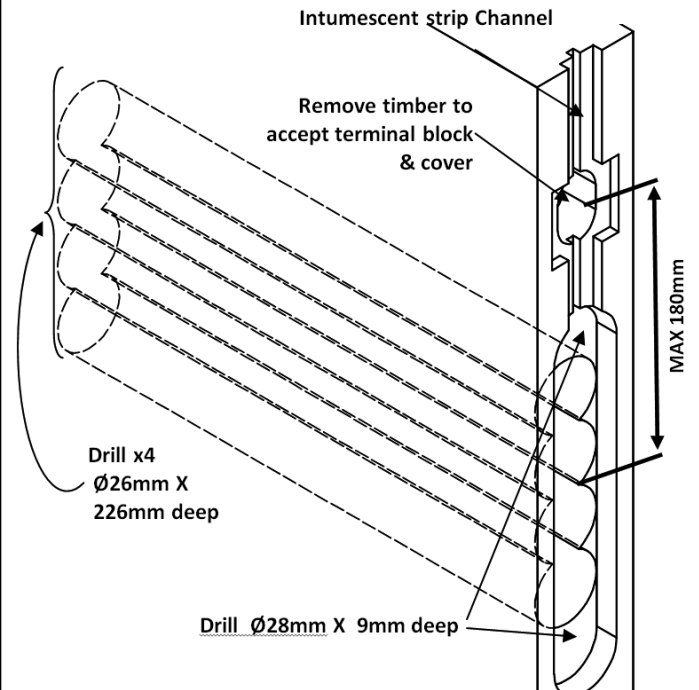

- Remove excess timber between drilled holes to accept the closer body and door plate.

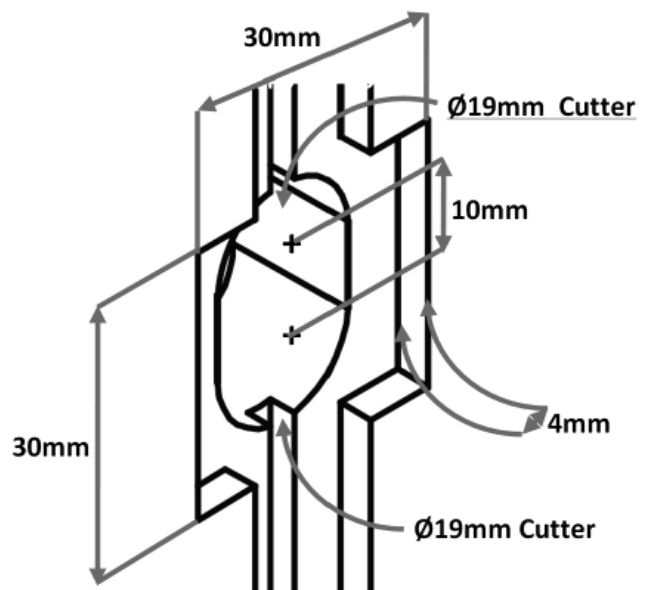

- Remove excess timber for intumescent strip and cable routing.

5 INSTALLING CLOSER

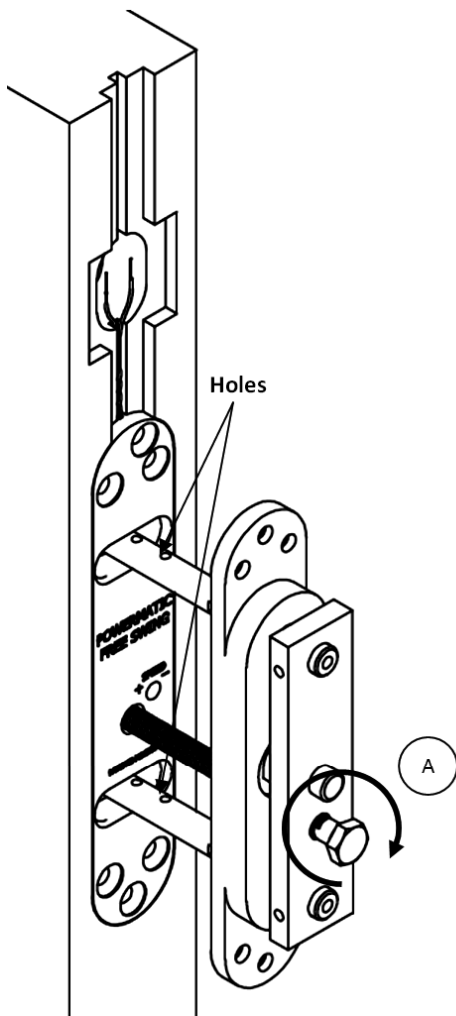

- Insert closer body into door, ensuring wire is free from obstruction.
- Insert extractor bolt (A) into position and rotate clockwise until holes in link rods appear.
- Generally for thicker doors expose both holes on each rod.

6 SECURING CLOSER

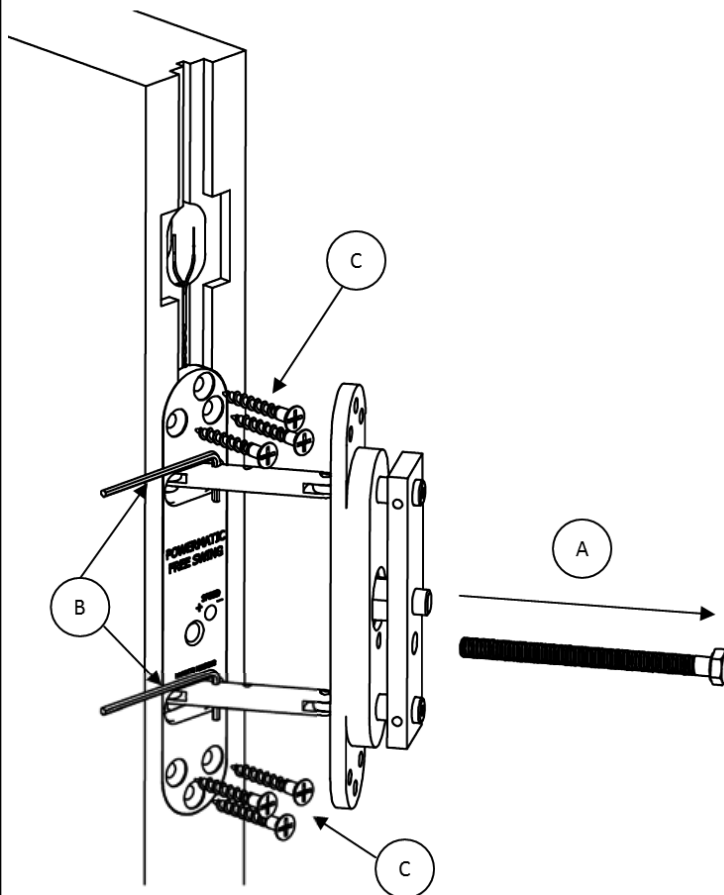

- Insert the allen keys (B) through both top and bottom link rod holes.
- **Both allen keys must be correctly located.**
- Remove extractor bolt (A).
- Secure door plate to door with six screws (C).
- **IMPORTANT**
For composite doors and door linings it is essential to drill pilot holes \varnothing 2.5mm to suit fixing screws.

7 SECURING FRAME PLATE

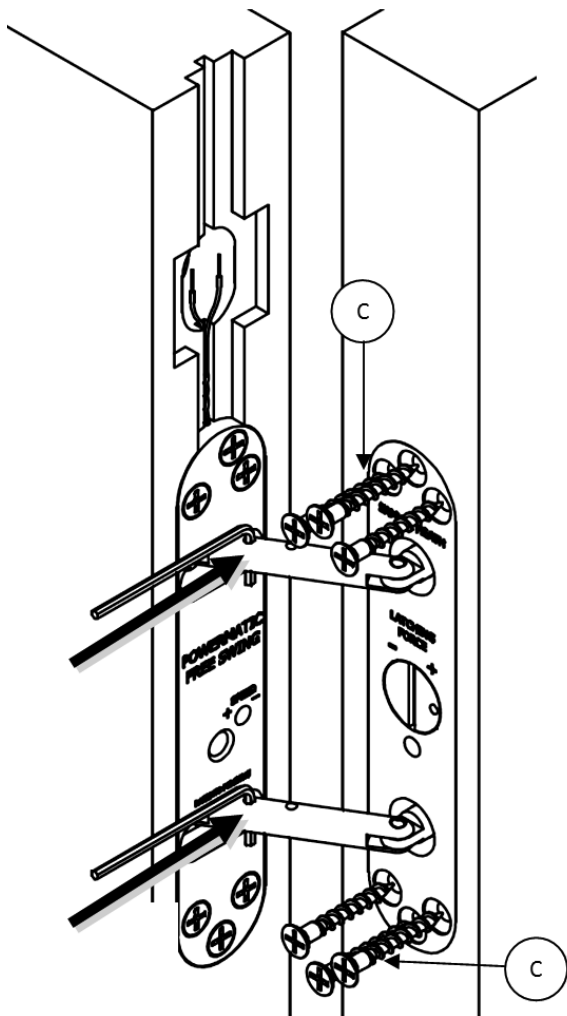

- With the closer secure and now held open by allen keys, if necessary firmly push both link rods across door plate and offer frame plate into frame void. Secure with six screws (D).
- With frame plate securely fitted open door slightly and remove allen keys.
- Installation is now complete.

8 ADJUSTMENT - CLOSING SPEED

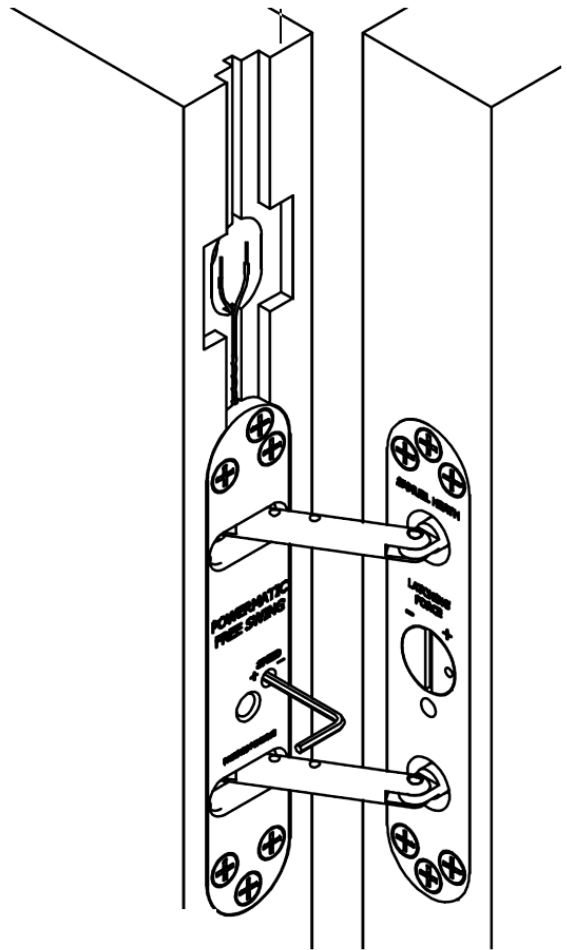

- Remove dust cap.
- Use one of the allen keys (B) to adjust closing speed.
- Positive (+) increases door speed.
- Negative (-) reduces door speed, as indicated on door plate.

9 ADJUSTMENT - POWER LATCHING ACTION

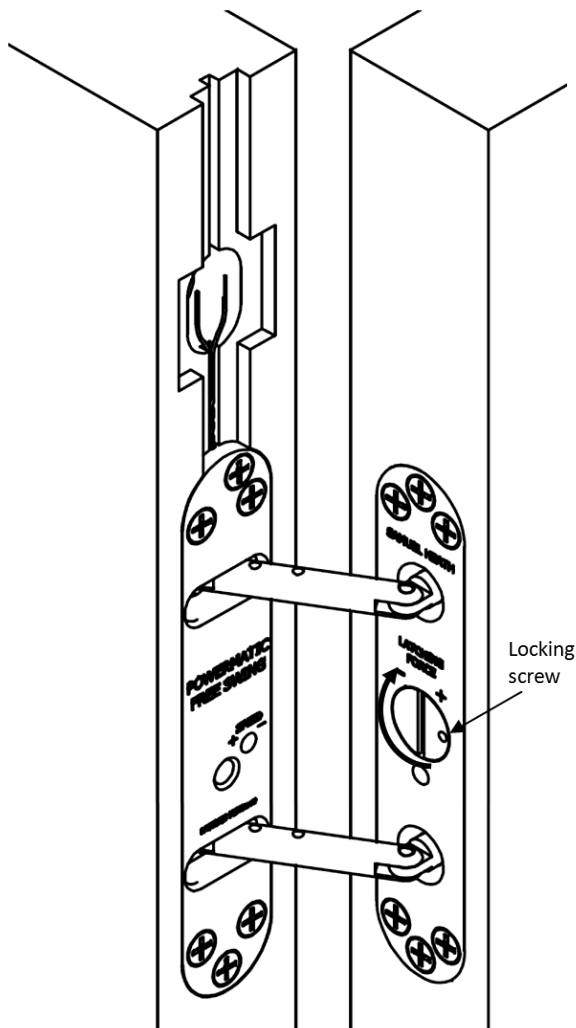

- The power latching action can be adjusted using a plain flat ended screwdriver.
- Loosen locking screw using allen key (D) to allow the adjuster screw to turn.
- Positive (+) increases the angle at which latching action engages. Negative (-) decreases angle at which the latching action engages.
- Re-tighten locking screw when correct power latching action achieved.

10 WIRING POWER SUPPLY

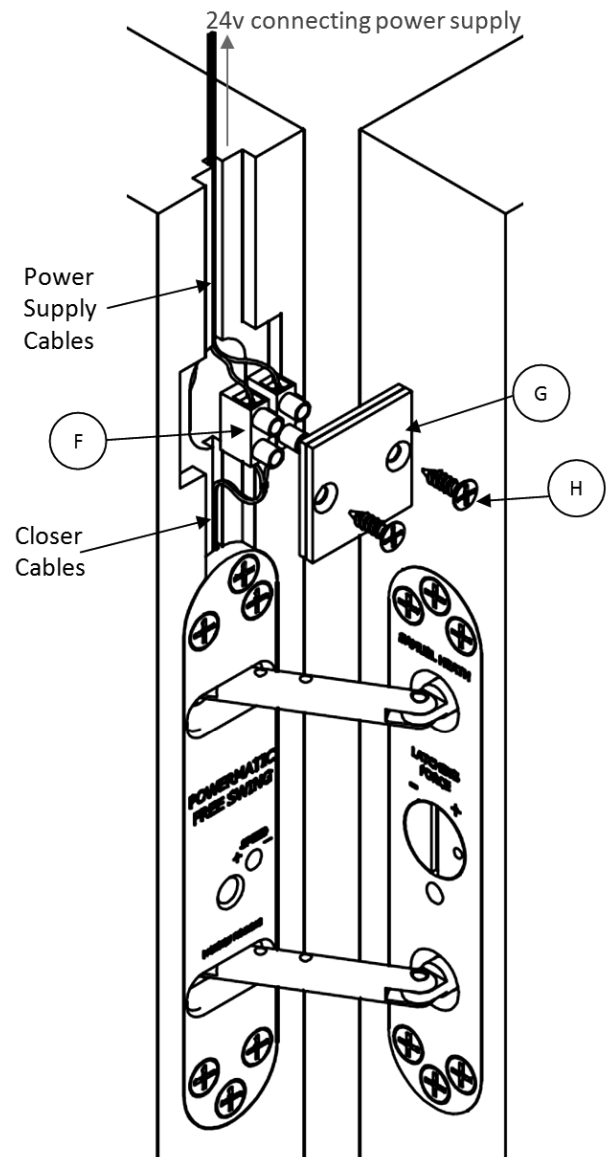

- Connect the closer to the power supply using the terminal block supplied.
- Push the terminal block (F) into the routed pocket and cover using the terminal plate (G) and screws (H).
- Conceal the cables in the intumescent channel void behind the intumescent strip.
- Ensure the wires are not damaged by the fixing screws.

11 OPERATION & FINAL CHECK

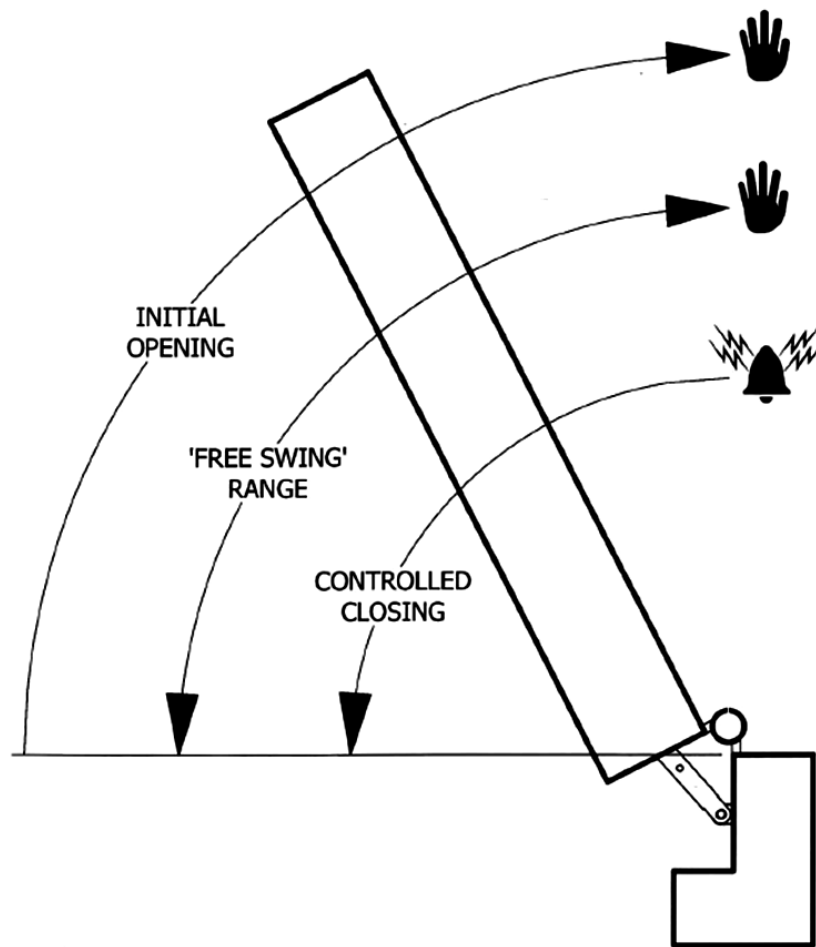

- To set the 'Free Swing' function with the 24v power connected, slowly open the door fully (taking into account the maximum opening measurement described at 105°). The mechanism will 'set' at this point. The door can now be opened and closed manually.
- It is recommended that the closing function is tested by turning the power supply off, at which point the door closer function will shut the door.
- Power should then be turned back on, and the Free Swing function engaged as described above.

MAINTENANCE

- Ensure that fixing screws remain tightly fastened.
- Ensure that all components on the doorset , i.e. latch, hinges ect are functioning correctly.

ELECTRICAL REQUIREMENTS

- This closer can be used to hold a fire door open 24 hours a day. It is recommended however that fire doors are closed overnight as the chance of a fire spreading undetected is greater during this period.
- It is recommended that an isolating switch is fitted nearby.

ELECTRICAL INFORMATION

SPECIFICATION

Power Requirements, 24v DC, 0.9A Nominal

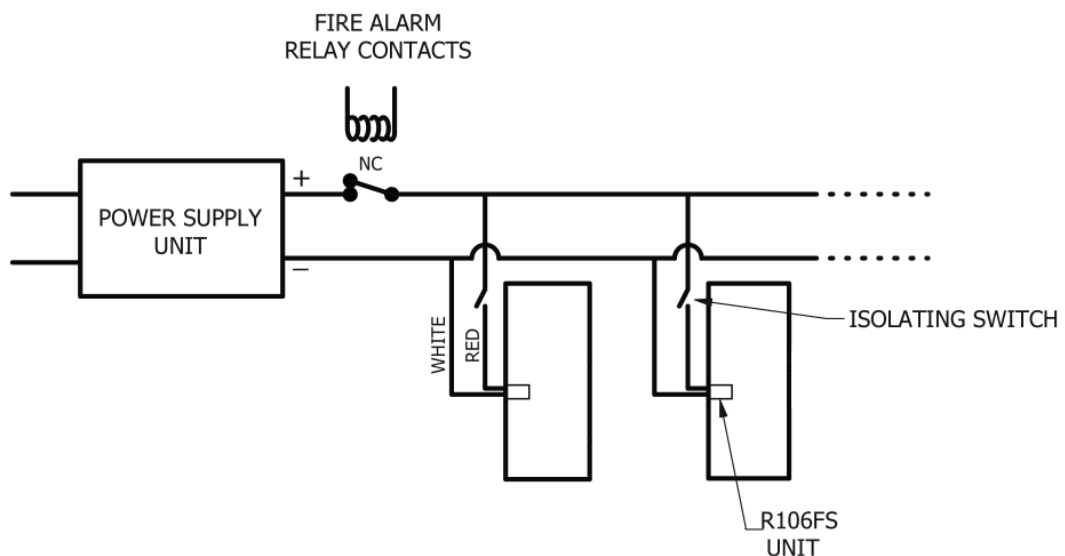

TYPICAL WIRING DIAGRAM

SAMUEL HEATH

since 1820

SAMUEL HEATH

Head Office and Customer Service
Leopold Street
Birmingham
England
B12 0UJ

T: +44 (0)121 766 4200

F: +44 (0)121 772 3334

info@samuel-heath.com

www.perko-powermatic.com